

A bio-inspired asynchronous pixel event tri-color

Juan A. Leñero-Bardallo, D.H. Bryn, P. Häfliger
hafliger@ifi.uio.no

vision sensor

UiO : Department of Informatics
University of Oslo

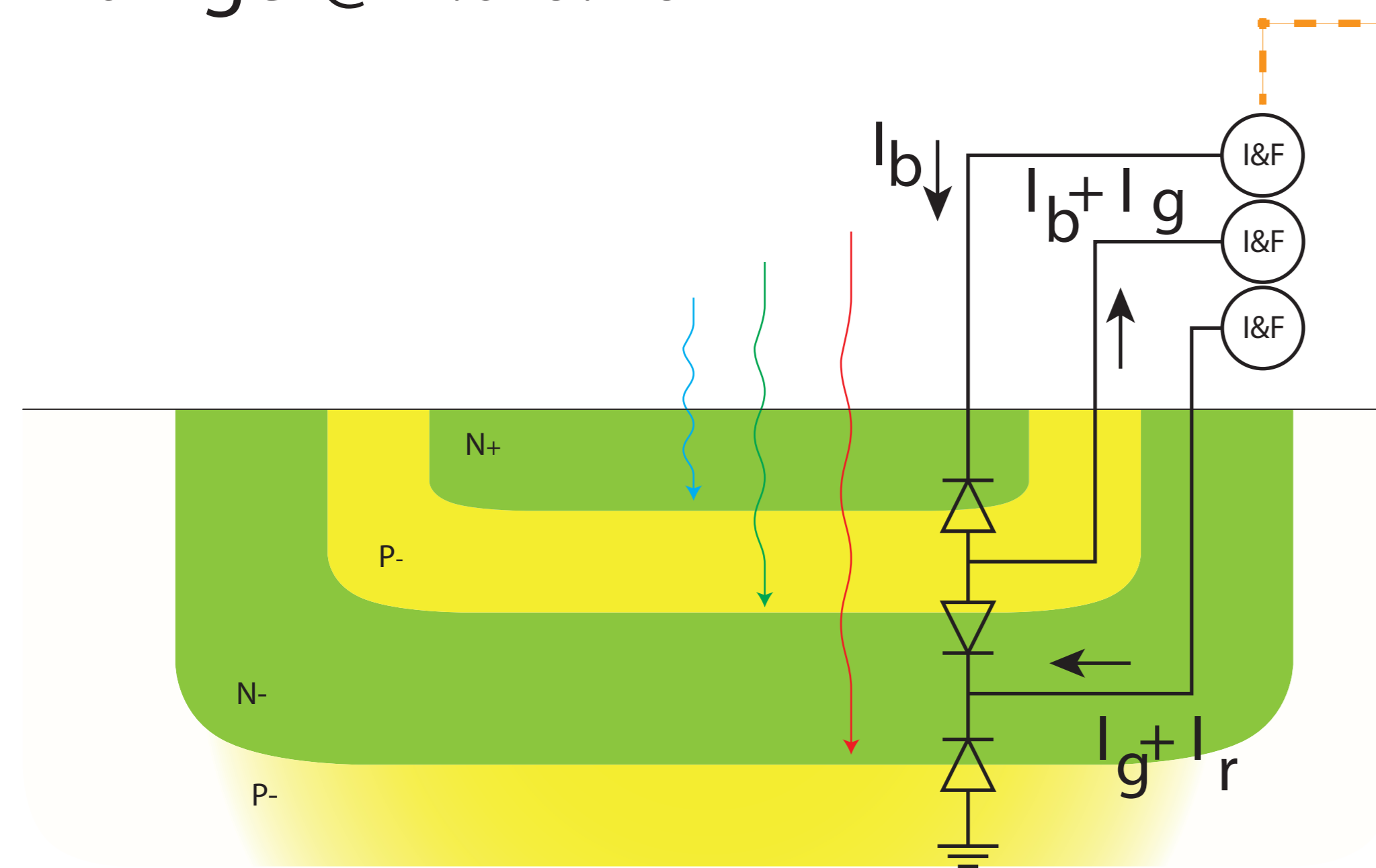

Fig. 1: Cross section of stacked photo diodes

This work:

New tri-color AER retina:

- Stacked photodiodes
- Low area and power consumption
- Robust color separation algorithm
- >Can be adapted to other technologies.

Array Size	22x22
Technology	STM 90nm
Power Supply	2.5V
Chip Size	1x1mm ²
Pixel Size	31x31um ²
Fill Factor	28%
Power Consumption	0.03mA@10Keps
FPN (RG Channel)	4.5%
FPN (GB Channel)	3%
FPN (B Channel)	5.8%
Dynamic Range	>60dB

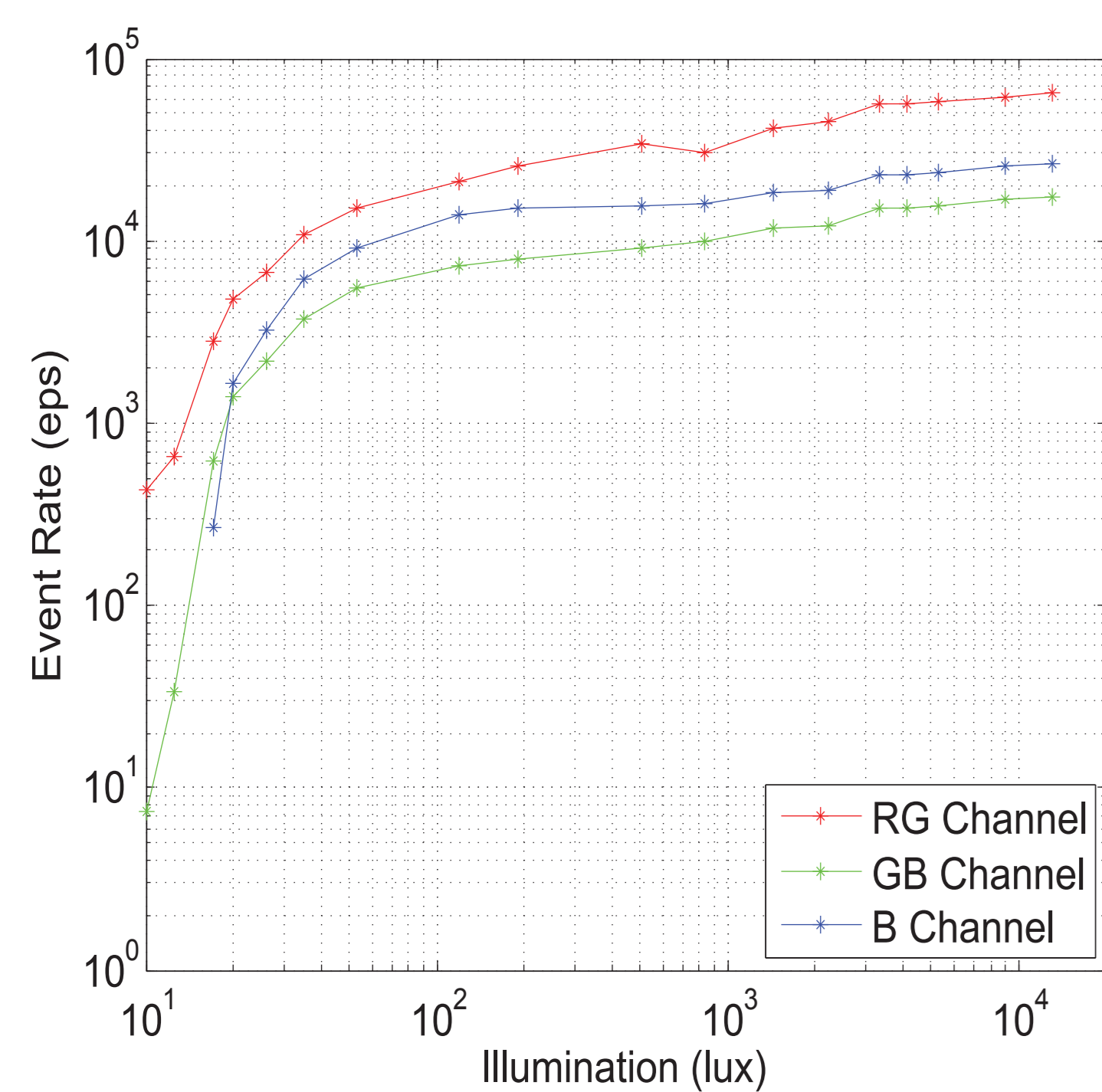

Fig. 5: Dynamic range

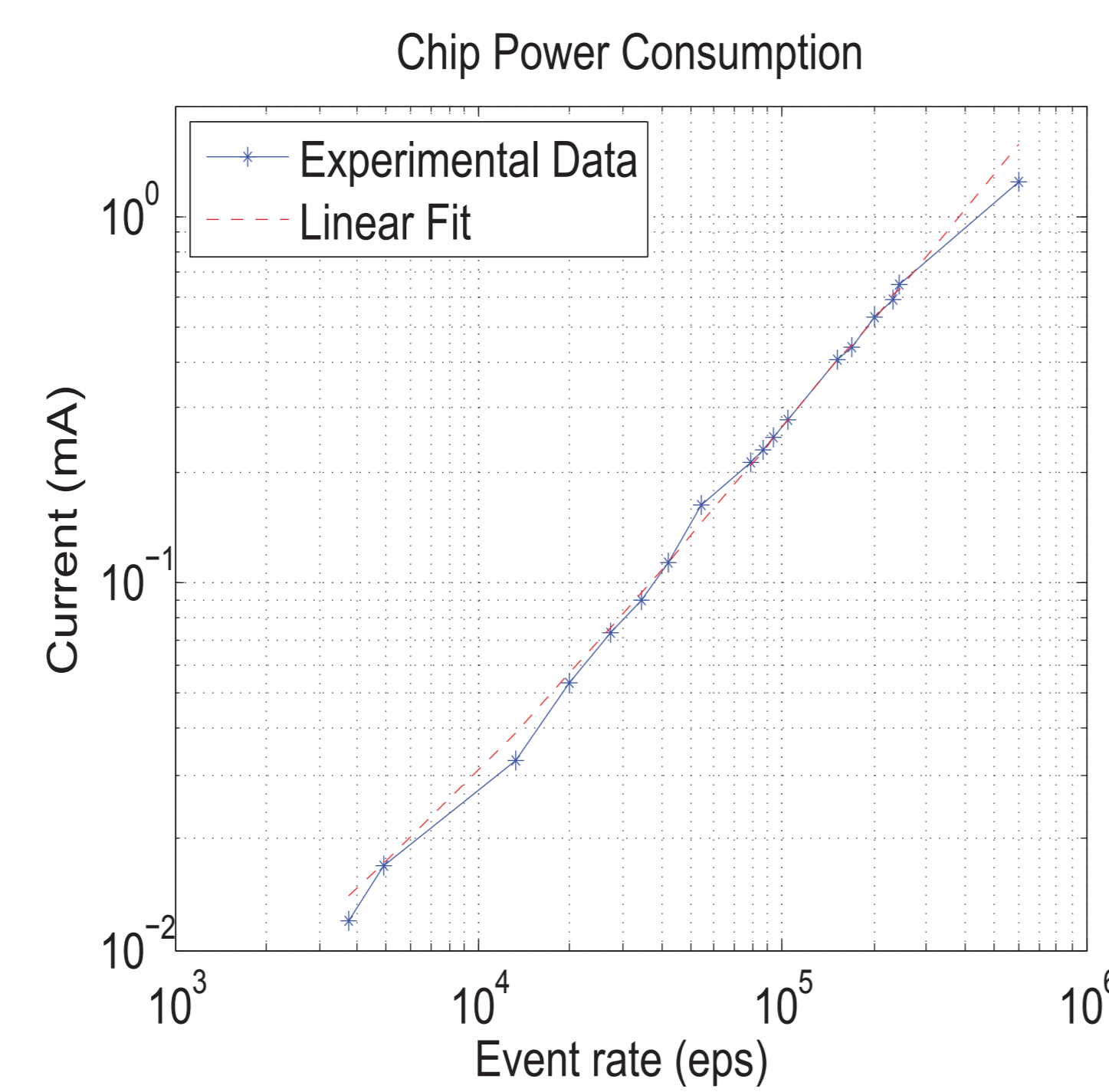

Fig. 6: Power consumption

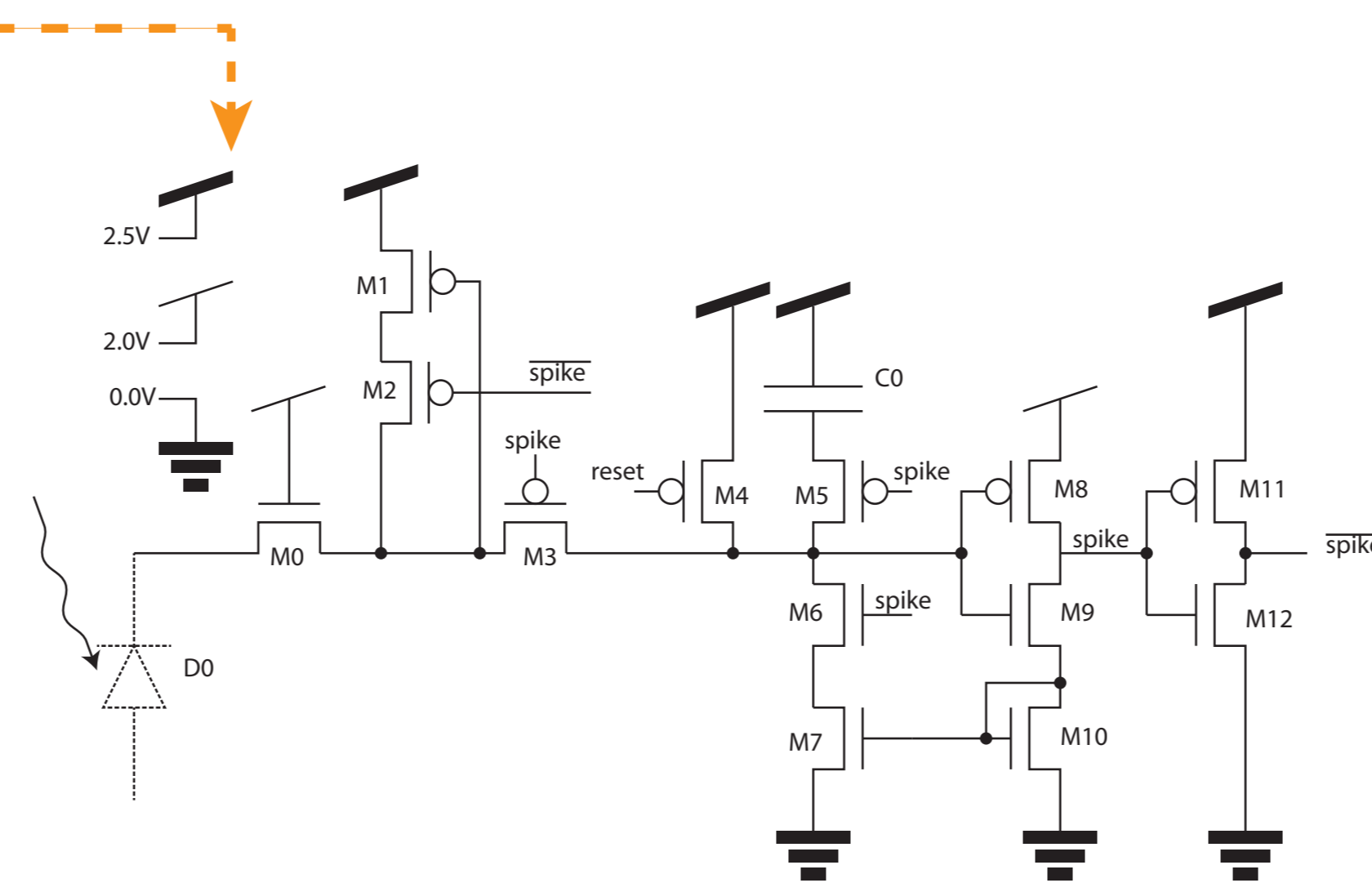

Fig. 2: Photo current leak/source integrate and fire neuron

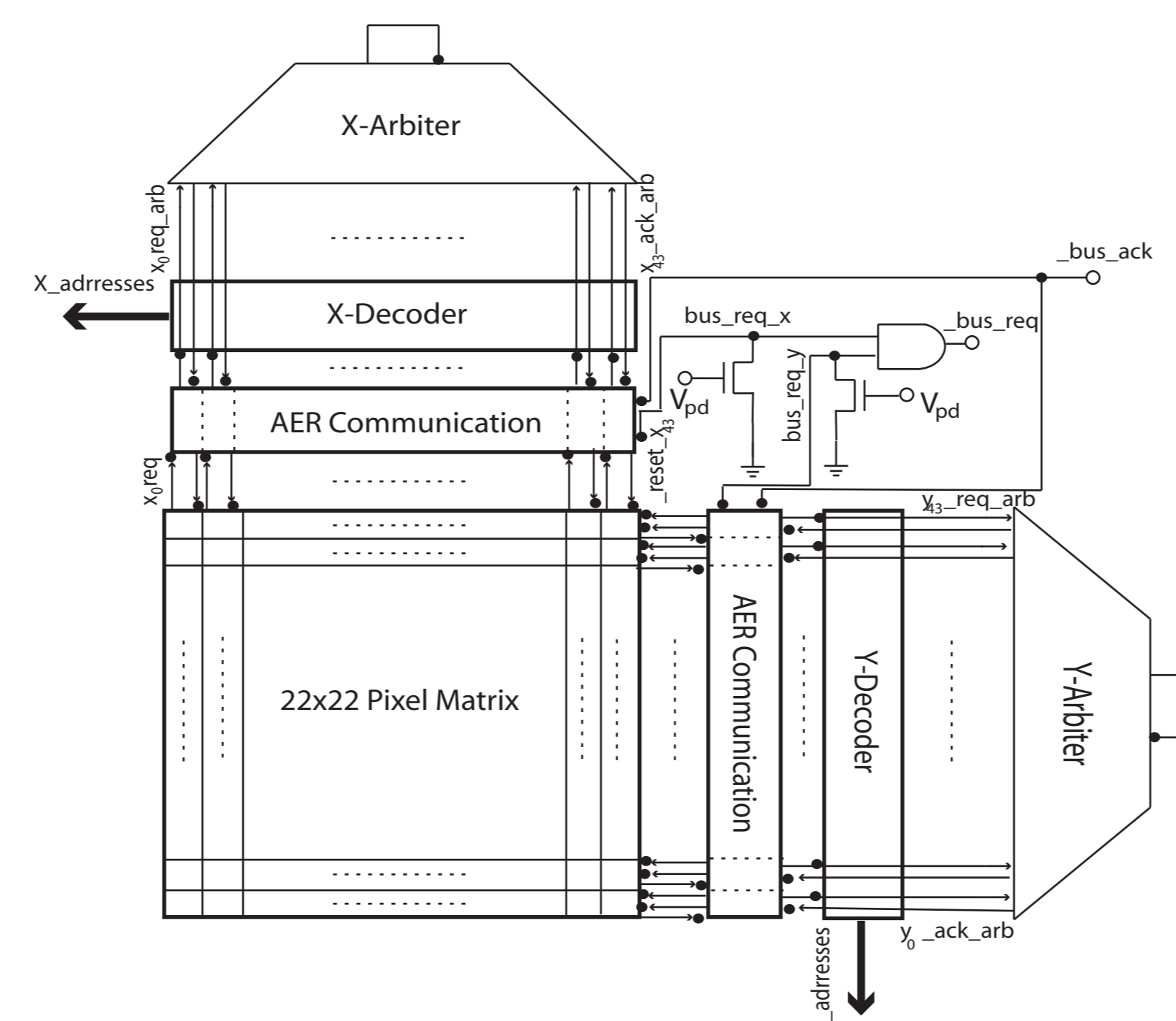
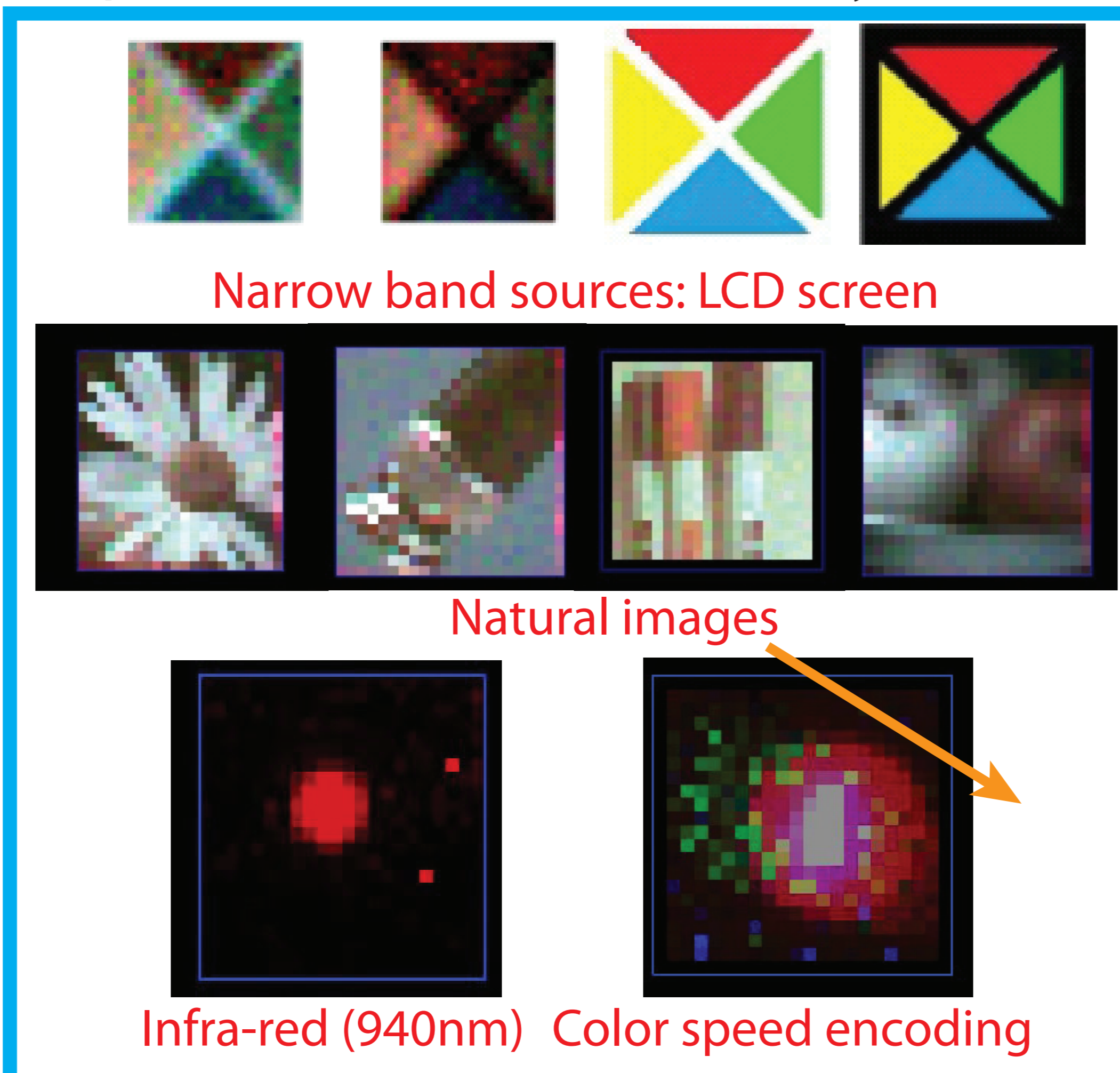

Fig 7: Overall System Overview

Example Data:

Color is perceived in a different way than we do



Color Separation Algorithm

1.- Measured output frequencies for each wavelength.
2.- Parameters C^* and e^* are tuned. They depend on the technology.
3.- Evaluation of the algorithm performance.

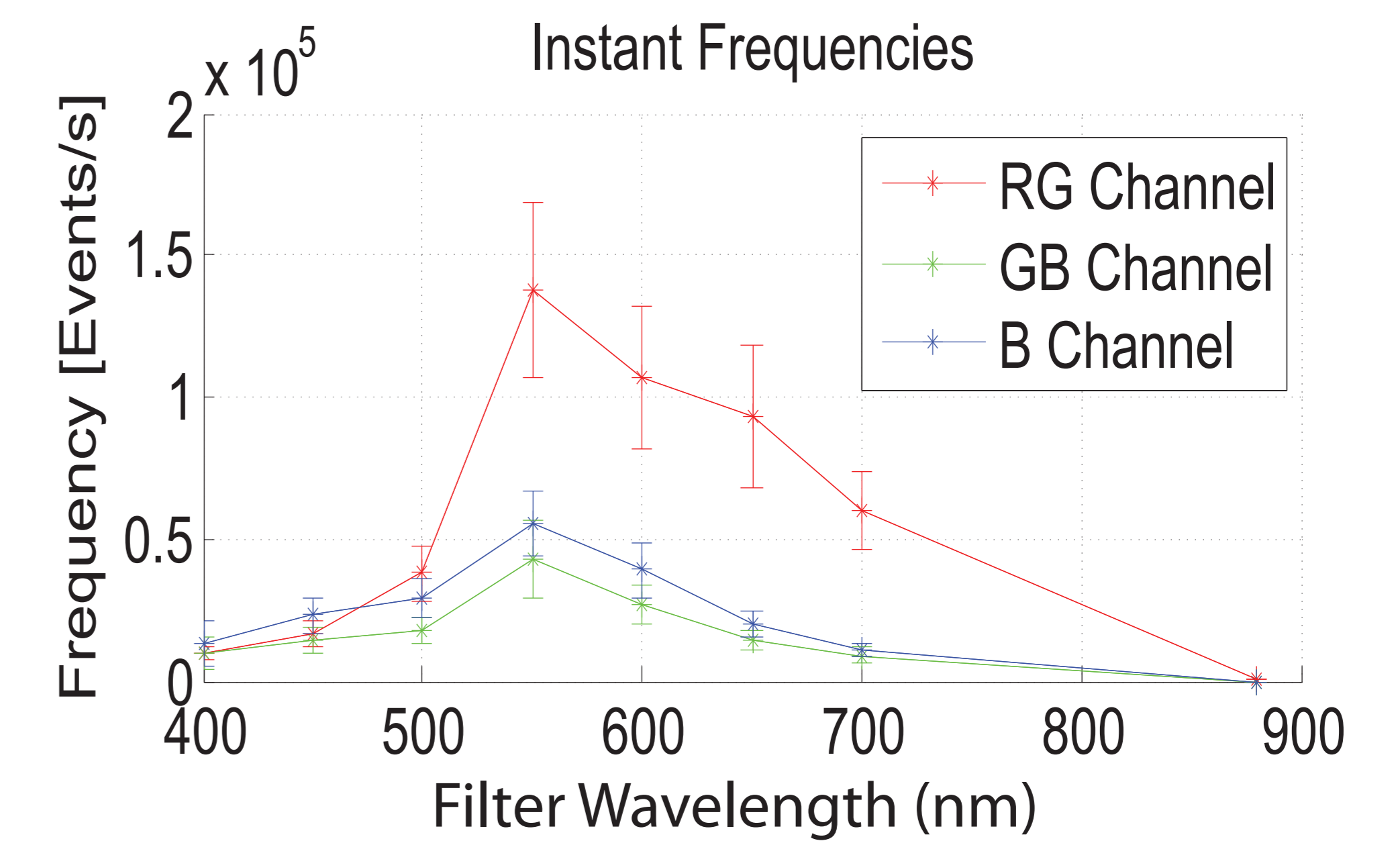

Fig. 3: Measured Frequencies for different wavelengths

$$E_B = f_B C_B / e_B$$

$$E_G = (f_{GB} C_{GB} - E_B e_B) / e_G$$

$$E_R = (f_{RG} C_{RG} - E_G e_G) / e_B$$

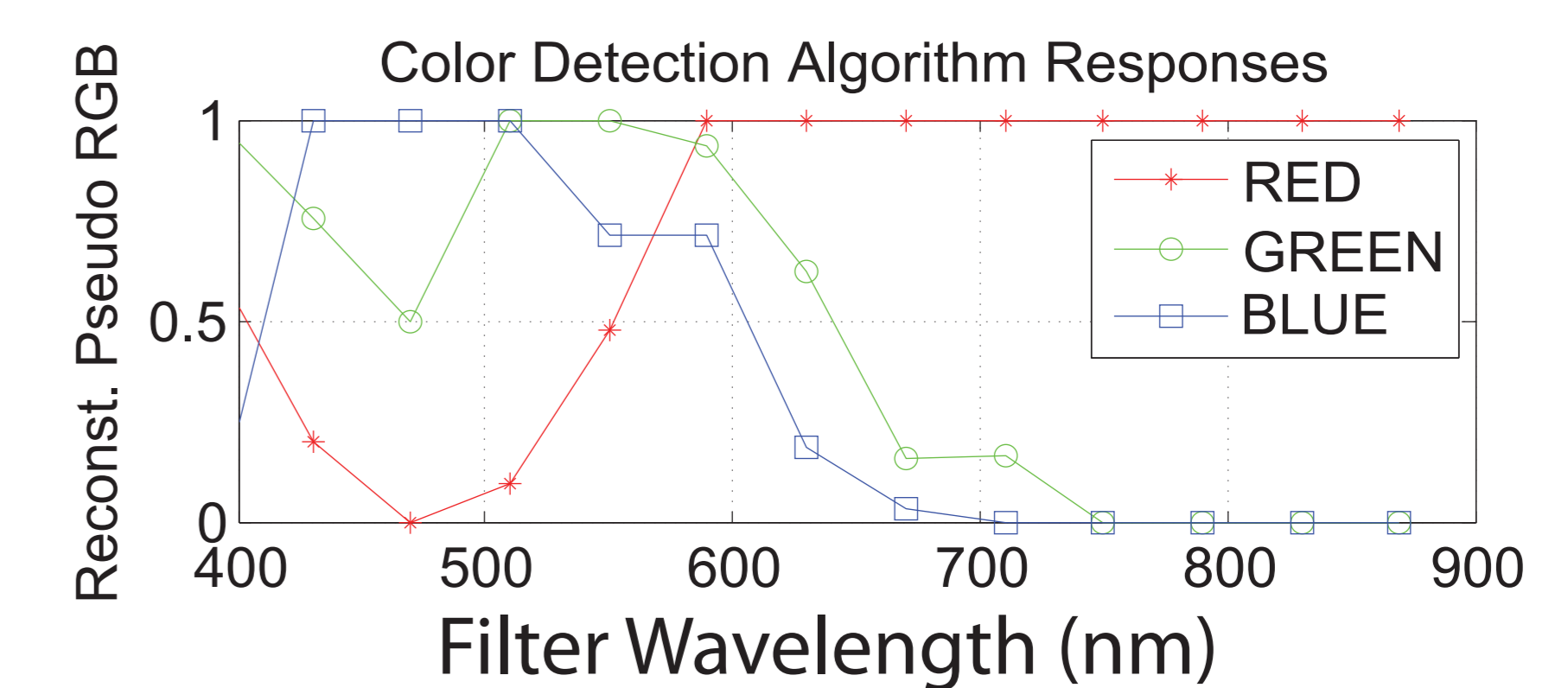

Fig. 4: Algorithm responses at different wavelengths. Results do not depend on illumination over 3 decades.